



Kanok Furniture & Decoration

# *QUALITY DRIVEN BY STRONG PRINCIPLES*

At Kanok, we have never wavered in our commitment to four core principles, which have guided us for over 40 years. Regardless of our business success, our commitment to these principles will never change.

- ⊗ Knowledge and expertise in our trade.
- ⊗ Honesty and integrity in management.
- ⊗ Determination to learn, progress, and innovate.
- ⊗ A strength of our reputation is the true measure of our success.

# *THE BEGINNING*

We have strong beliefs in striving for that crucial ingredient - quality

Kanok's founder, Pairaj Lertkangwarnklai, learned his craft in the 1950s as a young apprentice of renowned Shanghainese furniture manufacturer in Thailand. Even at that time, he noticed a lack of true quality, with many manufacturers willing to cut corners in the interest of greater profits.

Unwilling to compromise his principles, he founded Kanok in 1971 determined to never sacrifice the quality of his craft for the sake of profit. To ensure highest standards, Pairaj decided to keep all production work within Kanok foregoing the use of subcontractors. As a result, he has developed a wide range of skills and capabilities within Kanok.

To this day, his hands-on approach, dedication, integrity and eye for quality is evident in everything that bears the Kanok name.

# *40 YEARS OF GROWTH*

---

Strong principles and a clear vision have guided Kanok through 40 years of steady growth. From premium quality furniture to specialized interior fitting-out services, a strong reputation for excellence of craft has been established both in Thailand and abroad.

Through our experience projects ranging from luxury hotels, corporate offices, and private residences, we have developed our logistical and project management capabilities to the point where we can complete the most complex international projects, and manage country-specific challenges.

With our staff of 950, including 800 highly skilled craftsmen, we are able to handle projects of any size, complexity, and in any country from conceptualization through completion.



*SUPALAK FOONG*  
Director



*SIRILAK LERTKANGWARNKLAI*  
Director



*SIRAPAT LERTKANGWARNKLAI*  
Director

# *OUR STRENGTH*

## *OUR EXPERIENCED CRAFTSMEN*

The quality of our work is a direct reflection of the skills of our craftsmen and their dedication to excellence. At Kanok, we are committed to nurturing the growth of our craftsmen. We have not only accumulated a wealth of experience over the past 40 years, we have also made sure that this wealth of knowledge is passed on from one generation to the next ensuring continuity and growth in the skills of our people.



The reputation that Kanok has earned would not be possible if it were not for the expertise of our craftsmen.



# *OUR PRODUCTION CAPABILITIES*

---

## *IN-HOUSE PRODUCTION*

To ensure work of the highest standard, Kanok's policy is to produce everything in house and to never use subcontractors.

We have grown our production capabilities, which are currently comprised of 2 state-of-the-art factories equipped with the latest machinery.





Mock up will be made and tested in order to ensure that the work pieces are functioned properly. We completed all part included finishing in our factory to ensure quality and consistency. All items were finished to exact specifications and ready for installation when they leave our factory. This reduced time spent on site, and minimized any chances for errors.



### Unrivalled Experience

Like these chairs, all our projects are unique and present different challenges. Every project we complete gives us new and valuable experience that we can draw upon in the future.

## *OUR FACTORIES*

Our first factory is located in Bangkok and is over 10,000 m<sup>2</sup> in size. Our new second factory, approximately 100 km east of Bangkok, is over 32,000 m<sup>2</sup> and will be our base for mass production, door manufacturing, and export.

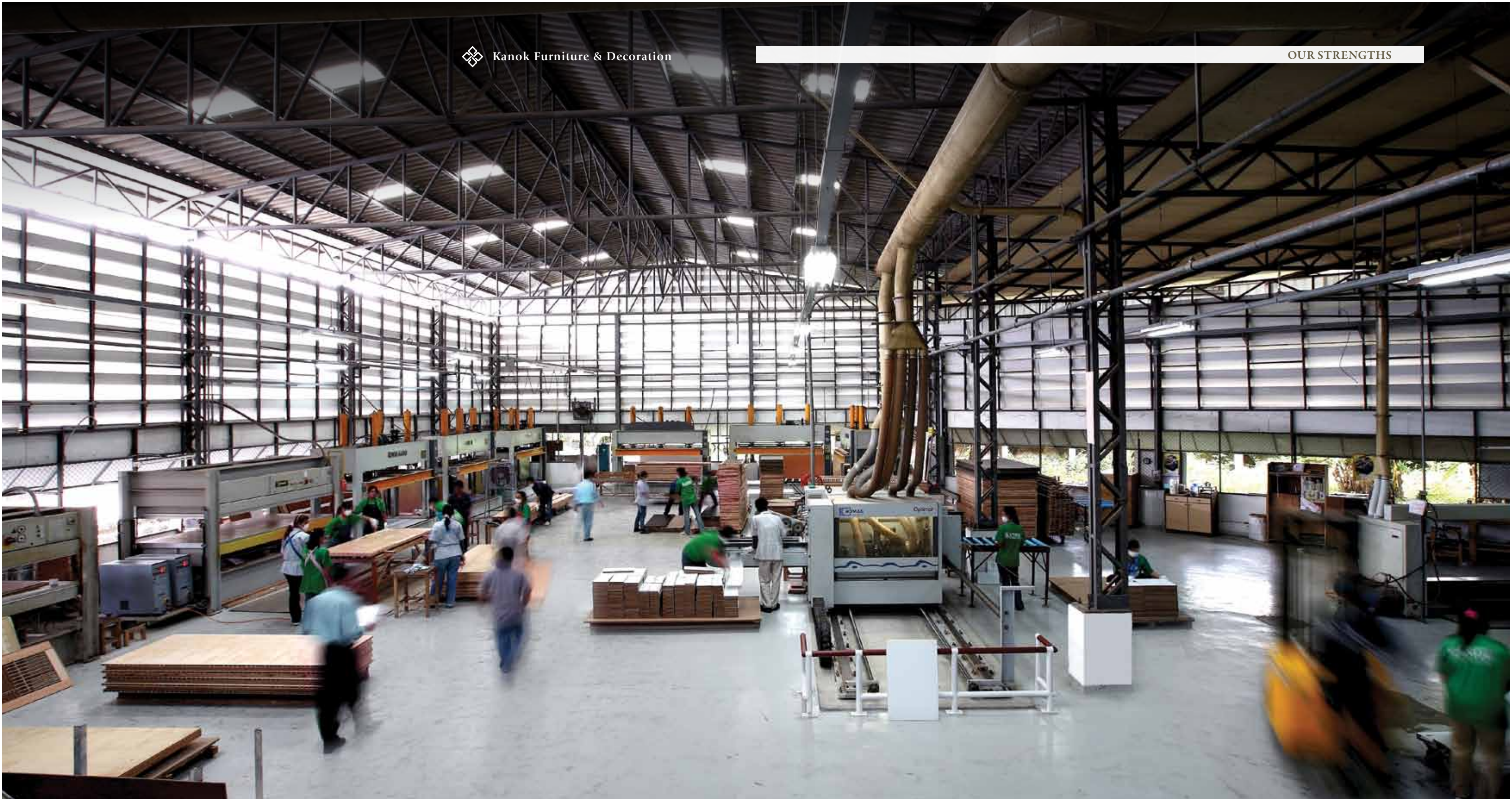

## *MODERN MACHINERY*

Our factories are equipped with the latest machinery, imported from Italy and Germany – countries renowned for the quality of their woodworking machinery



## *PRODUCTION PROCESS*

We assure excellence in all stages of production, from preparation to production and finishing. Our factories are fully equipped allowing us to complete production of materials at the factory, minimizing work and installation time on-site. This gives us full quality control and let's us minimize production time and the number of staff required to work at project sites.



# 1 PREPARATION

Preparation begins with selection of the appropriate wood and cutting it to size in preparation for Planing. Planes are tools used to flatten, reduce thickness, and give rough lumber a smooth surface. We use various special types of planes for different types of product details.



# PRODUCTION

We have various machines at our disposal during the production process, to be used for cutting and drilling, pressing, edge banding, and NC routing.

## PRESSING:

We use a hydraulic machine with a hydraulic cylinder to generate compression force. Our pressing work is of global standards for bending tolerance, bonding, and wave limitations. Hi-bonding glue and re-agents are used to achieve optimal bonding force and guarantee a smooth surface.



Pressing Machine



Edge Banding Machine



Edge Banding Machine



**CUTTING:**

Our use of CAD/CAM systems integrated with panel saws controls the cutting procedure, ensuring work of +/- 0.1 tolerance.

**DRILLING:**

In modern CNC systems, end-to-end component design is highly automated using computer-aided design (CAD) and computer-aided manufacturing (CAM) programs. In the process of making any lockset, hinge, furniture or door handle (all ironmongery), tennon and joint with the integrated CAD/CAM system.



CNC Machine



# 3

## FINISHING

### FINISHING:

We have a fully-automated finishing system that begins with automated dust-free spray painting line that allows us to finish all pieces of work to a precise and consistent thickness. Combined with an infrared heating tunnel, we are able to produce more than 100,000 pieces annually.



Automatic Spray Paint Machine



# *TURNKEY SOLUTIONS*

---

As projects become increasingly more complex, Kanok's full service capabilities ensures simplicity, efficiency and quality. By engaging us from conceptualization, blueprint development through production and installation, we manage the complexities of your project for you, saving time, money, and guaranteeing your satisfaction.



*Project Planning*



*Design Development*



*Professional Project Management*

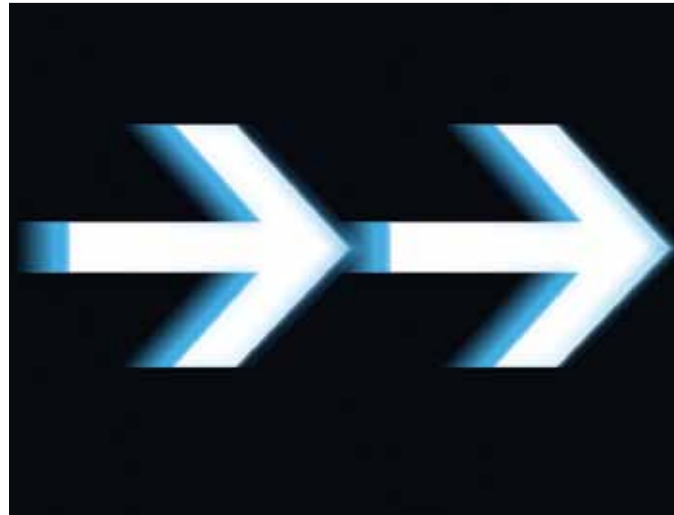

*Factory Base Production*



*Mass Customization*



*Global Experience & GlobalSourcing*



The nature of the projects that Kanok undertakes can be very complex. To ensure that we can be creative, hit our deadlines and maintain our high quality expectations, we offer a full service solution.

## *BLUEPRINT & PRODUCT DEVELOPMENT DEPARTMENT*

Our in-house development team has worked together for more than 10 years and is fully equipped with the latest software and expertise to fulfill customers' blueprint and product design needs.



## *GLOBAL SOURCING*

Our sourcing capability has no boundary. From our experience and knowledge bank, we can offer our customers the best value possible. We know how to source the right materials at the right prices, and more importantly how to use these materials properly in order to deliver high quality solutions that really work, and do so at highly competitive prices.



## *PROJECT MANAGEMENT*

With more than 40 years experience managing large projects, the Kanok management team ensures all projects are administered efficiently and effectively, transforming plans to reality on time and with superior quality.



## *PRODUCTION TEAM*

Having completed more than 200 projects our production team has a wealth of experience. Combined with state-of-the-art equipment, our experienced craftsmen are the key to our customers' satisfaction.



## *FINANCIAL STABILITY AND CREDENTIALS*

Throughout our history, Kanok has shown consistent growth even during times of economic downturn. We have managed to learn from the most challenging of times and come out a stronger organization. We are accredited and receive the support of several major banks, such as BBL, UOB, HSBC, SCB, and CIMB, which ensures that all our projects around the world have a stable financial foundation.

# *OUR VALUES*

---

Great design demands vision, creativity, an understanding of materials and form, and keen eye for detail; building that design demands one thing – **experience**.

With over 40 years experience, Kanok brings designs to life with exceptional quality. It is a perfection that can be felt in every interior space we craft.

## Attention to DETAIL

### PHULAY BAY, A RITZ-CARLTON RESERVE

Designed by a leading Asian designer, The Ritz Carlton, Krabi, is Thailand's first Six-Star hotel, featuring all luxury suite accommodations.

Every aspect of its interior is meticulously crafted, drawing upon the rich experience of our master craftsmen.

This project features a unique and intricate domed ceiling, which requires the production of a precise steel structure, which is much more complex than conventional ceiling mounting methods. It could only be realized through the work of Kanok's shop drawing team combined with specialized techniques, experienced know-how, and effective project management.



The hotel features meticulously crafted design artwork, such as the special paint work and custom-molded sanitary-ware featured in the bathrooms, all of which combine beauty and durability seamlessly.

The result is a stunning work of art that could not have been achieved without an uncompromising attention to detail and a clear and precise development plan.

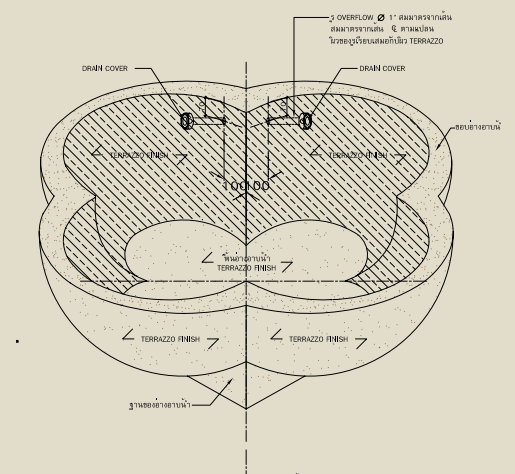
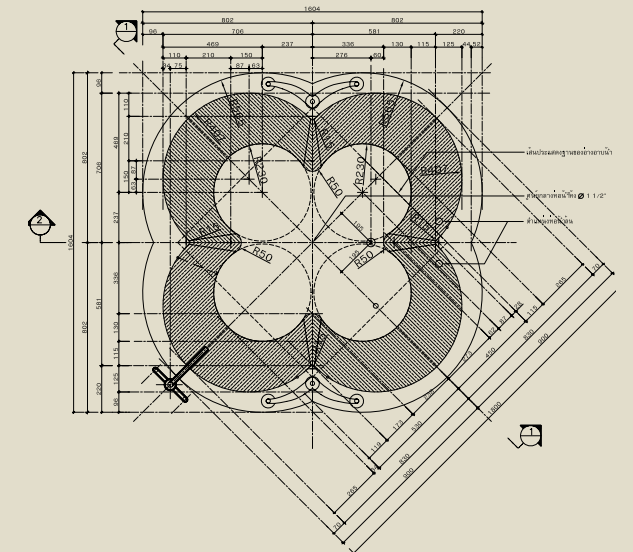
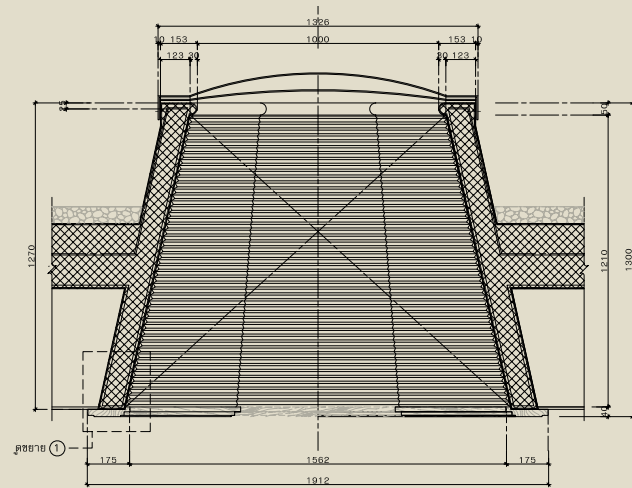
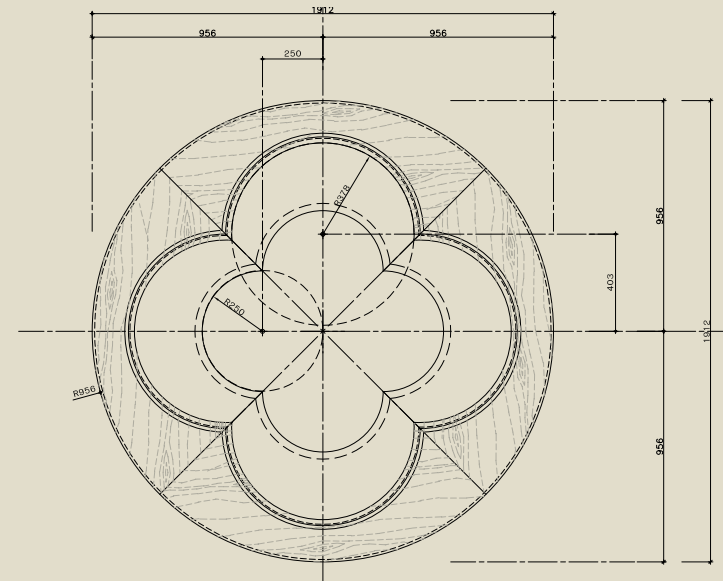

# Precise PRE - ASSEMBLY

CONRAD SAMUI  
THAILAND

This large project consists of 65 rooms, restaurants and spa with a touch of Thai style. Luxurious, distinctive and unique, its design is exquisitely detailed and could only be realized with the skill of master artisans. The project is located on a beautiful, yet challenging, hillside overlooking the ocean, where guests can enjoy limitless views of the sea. Kanok's project management and coordination skills were key to the success of this difficult project, where strict timelines, obstacles such as unpredictable weather, and difficult terrain all combined to create extreme challenges.

LEFT |  
SITE SLOPE



ABOVE & OPPOSITE PAGE| CEILING DETAIL

BELOW | WOOD WORK DETAIL



Behind the delicate details of the flowery decorative ceiling panels is a framework made of lightweight steel, designed to be durable, strong, and long lasting. This ceiling has a multi-layered look, created by overlapping layers of decorative lighting for an eye-catching visual effect. The production and assembly of the specialized moldings requires meticulous craftsmanship in the production of shop drawings, plus a careful planning execution in all stages of production.

All timber and metal components are inspected to eliminate any imperfections before fabrication in order to ensure the highest quality and time efficiency. All production and finishing is completed before installation on site by our expert technicians.

The beautiful flowery decorative ceiling is the result of a sophisticated design and complex production process. It embodies Kanok's refined skills and special techniques. The design adds a sense of softness to the ceiling and is complemented by lighting effects.

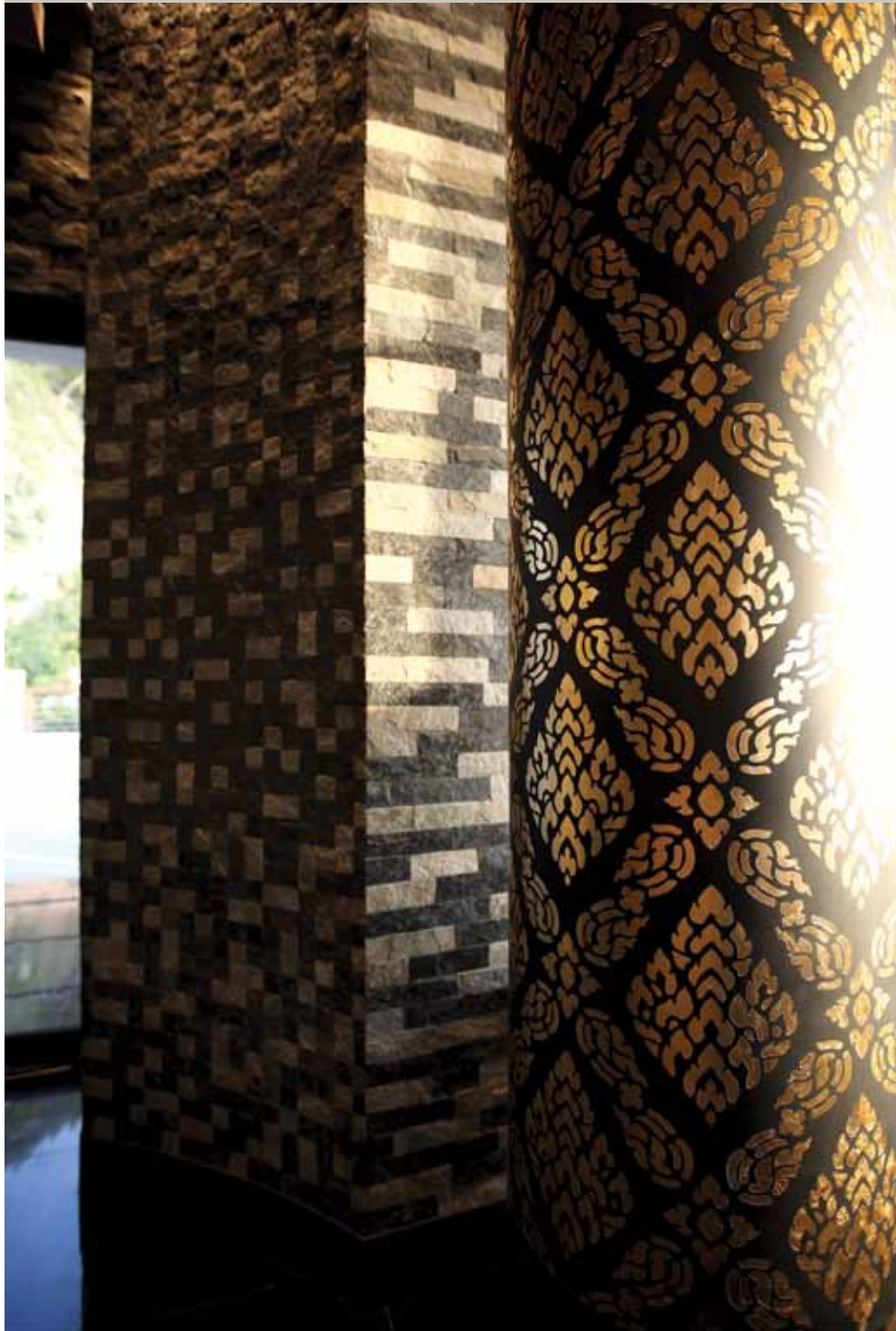

These magnificent gilded columns display intricate patterns created with gold paint, applied by the hands of our expert craftsmen.

Highlighting this project are the stone walls, displaying unique patterns created through the layering of small pieces of different types of rocks to an exquisite effect. They are unique and beautiful pieces of art created by the fine skills of our artisans.

**LEFT |**  
HAND PAINTED COLUMN



Due to Thailand's climate, which causes wood to dramatically expand and contract, the 'free form lattice ceiling' created by Kanok required exactness in measurement of selected timber as well as precise skill and expertise in installation. Only the wood of the finest quality was selected, and then cut with precision with a high-tech saw to ensure uniformity of size and shape as well as a smooth surface. Our technique proved faster, and reduced unwanted error when compared to more conventional techniques.



**ABOVE |**  
LATTICE CEILING

We completed all paint finishing in our factory to ensure quality and consistency. All items were finished to exact specifications and ready for installation when they leave our factory. This reduced time spent on site, and minimized any chances for errors. The main challenge in the installation of the free form lattice ceiling was in making sure of the perfect alignment of the wooden lattice and the light fixtures, which was the key to make sure the mood intended by the designer was delivered.



The fine decorative wall has the appearance of a carved partition. The design is meant to look simple, but in fact is the product of a very thorough and complicated process beginning with timber sorting and selection, computerized cutting and trimming of the wood in preparation, through finishing to exacting precision. Expert installation ensures precise alignment of each piece.



**RIGHT |**  
DECORATIVE WALL



